

Installation

Step 1 - Identify Suitable Location

Before making any permanent fixtures Warmup recommends identifying your preferred location for the MSTAT. It should be located in an area with good ventilation. It should not be beside a window/door, in direct sunlight or above another heat generating device (e.g. radiator or TV).

BATHROOM INSTALLATIONS: When installing a MSTAT within a bathroom it MUST be mounted outside of Zone 2 in accordance with the Wiring Regulations. If it is not possible to identify a suitable location outside of Zone 2 within the bathroom, then it is recommended that the MSTAT is installed in the adjacent room and set to control the heating by floor temperature only. When installed in this way, it is not possible to directly control the heating based on the room air temperature, only the floor surface temperature.

Step 2 - Dimensions

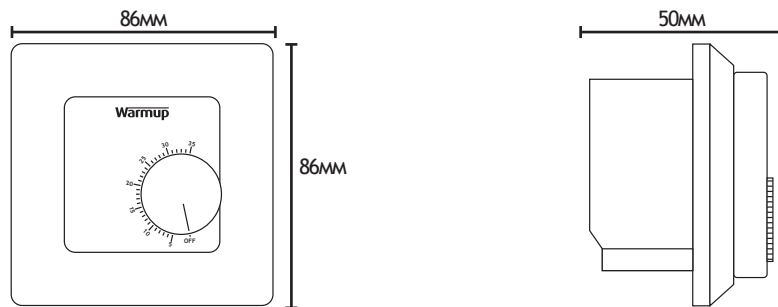

Step 3 - Components

1. Heating indication - concealed LED (red)
2. Release clip - to remove cover
3. Temperature dial - range Off, 5°C to 35°C

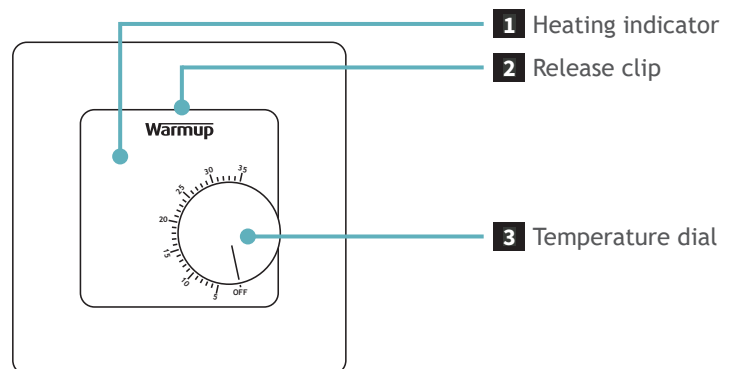

Step 4 - Installation

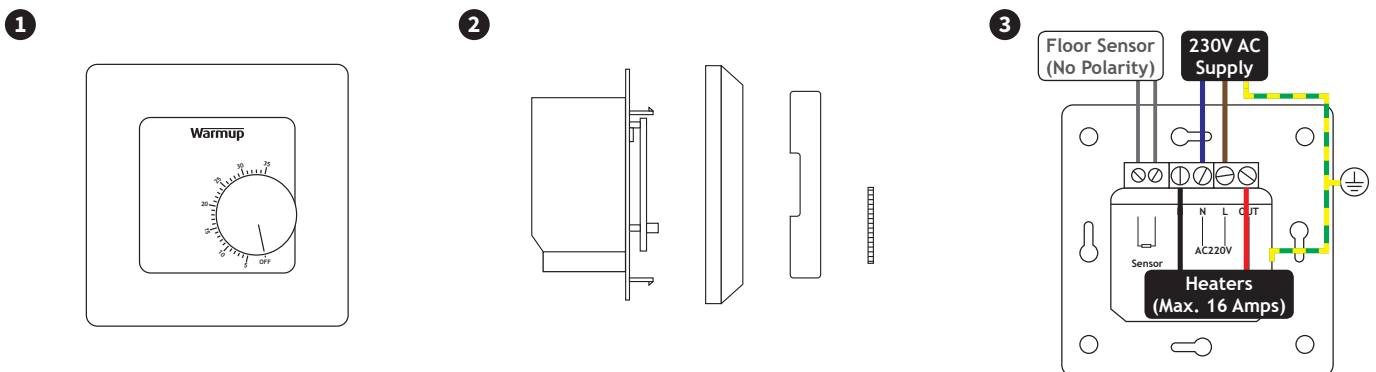

1 Gently remove the dial using a small screwdriver, followed by the cover inserting a small screwdriver into the release clip

2 Remove the front fascia by un-clipping from the base and placing somewhere safe

3 Wire as show and install to a 35mm deep (min.) pattress box

Technical Specifications

- Operating Voltage - 230V AC ±10% 50Hz
- Max. Load - 16A (3680W)
- Dimensions - (H/W/D): 86 x 86 x 50mm (from wall)
- Sensors - Air & Floor
- Sensor Type - NTC5K 3m long (can be extended to 50m)
- Insulation Class - II
- IP Rating - IP40
- Installation Depth - 35mm back box
- Heating Indication - LED
- Compatibility - eUFH, hUFH & Central Heating
- Er-P Class - I
- Standards - EN60730-1 & EN60730-2-9

Configuration

The MSTAT can be configured to use either the built in air sensor, the 5k external floor sensor or a combination of both. The thermostat also has the function to reduce the factory set maximum floor limit. All of these settings are altered by moving jumper connectors on the PCB, marked K1/K2/S3. See below for configurations;

Internal sensor only



This configuration will use the internal air sensor.

External sensor only

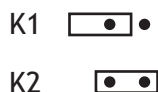

This configuration will use the external floor sensor.

Both internal and external sensors

(Default Configuration)

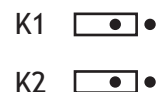

This configuration will use the internal sensor as the temperature control sensor and external floor sensor as a floor limit sensor.

The thermostat has a feature which allows it to automatically detect if a sensor has a fault. Should either sensor develop a fault, the thermostat will automatically default to a safe mode, which cycles the heating on for 2 minutes and off for 2, reducing the power from maximum to 50%.

S3 closed



This configuration will set the interface temperature limit to 35°C, with the floor surface temperatures as per the table opposite.

S3 open



This configuration will set the interface temperature limit to 27°C, with the floor surface temperatures as per the table opposite. This setting should be used for vinyl.

Floor Surface Temperatures		
Floor Finish	S3 Closed	S3 Open
10mm Tiles	34°C	26.5°C
4mm Vinyl	n/a	26°C
7mm Laminate	n/a	25°C
14mm Engineered	27.5°C	24°C
6mm Contract Carpet	29°C	24.5°C
15mm Carpet & Underlay	26°C	23.5°C

*This table should only be used as a guide. All figures shown in this table are based on a design room temperature of 21°C and estimated floor finish resistances.

Operation

On - Rotate the dial clockwise to required temperature

Off - Rotate the dial anti-clockwise to the 'off' position

When the heating is active, the heating indicator will be lit.

Warranty

Warmup plc warrants this product, to be free from defects in the workmanship or materials, under normal use and service, for a period of three (3) years from the date of purchase by the consumer. Extended lifetime warranties are available for the MSTAT. For further information, enquire at your local MSTAT retailer, check online at www.warmup.co.uk or contact Warmup directly on 0345-345-2288. For full warranty information please see the extended manual online at warmup.co.uk. To register your warranty please visit warmup.co.uk

Contact Details

Jovis 98 Trading SRL, Strada Gorunului, 10, Sectorul 1, Bucuresti, 012627 T:+4 0744 654 067 • E-mail: office@jovis98.ro . WEB www.jovis98.ro